

# Cap Coil Nailer

Model No: CN90CP

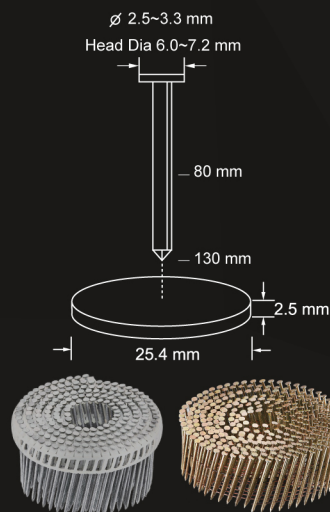

Model No	CN90CP
L x W x H	300x130x330 mm
Weight	3.6 kgs
Head Dia	6.0~7.2 mm
Shank Dia	Wire coil nails: 2.5~3.3 mm Plastic coil nails: 2.5~2.9 mm
Fastener Range	83~130 mm
Magazine Type	Convex type
Capacity	Wire coil nails: 400 pcs Plastic coil nails: 200 pcs
Operating Pressure	100~120 psi



## APPLICATION

- Roofing felt
- Foam and fiberboard sheathing
- Insulation house wrap cardboard or carton to pallet

## FEATURES

- 360 degree exhaust deflector allows exhaust of air in any direction
- Depth of adjustment to countersink of flush drive nails
- Lightweight design prevents arm fatigue for user
- Drives wire and plastic sheet collated nails
- Use plastic cap, metal cap, stainless cap waterproof stainless cap

# Cap Coil Nailer

Model No: CN75CP



Model No	CN75CP
L x W x H	300x130x318 mm
Weight	3.3 kgs
Head Dia	6.0~7.2 mm
Shank Dia	Wire coil nails: 2.3~2.9 mm Plastic coil nails: 2.3~2.5 mm
Fastener Range	Wire coil nails : 45~57 mm Plastic coil nails: 38~75 mm
Magazine Type	Convex type
Capacity	Wire coil nails : 400 pcs Plastic coil nails : 200 pcs
Operating Pressure	100~120 psi

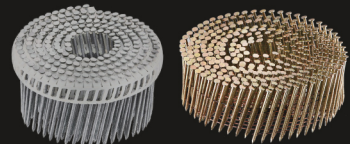
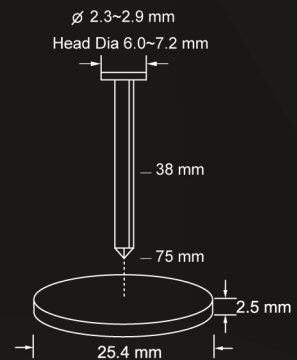

## APPLICATION

- Roofing felt
- Foam and fiberboard sheathing
- Insulation house wrap cardboard or carton to pallet

## FEATURES

- 360 degree exhaust deflector allows exhaust of air in any direction
- Depth of adjustment to countersink of flush drive nails
- Lightweight design prevents arm fatigue for user
- Drives wire and plastic sheet collated nails
- Use plastic cap, metal cap, stainless cap, waterproof stainless cap

# Cap Coil Nailer

Model No: CN65CPA, CN65CPB



Model No	CN65CPA	CN65CPB
L x W x H	300x130x330 mm	
Weight	3.6 kgs	
Head Dia	6.0~7.2 mm	5.0~6.0 mm
Shank Dia	2.5~2.9 mm	2.1~2.5 mm
Fastener Range	32~65 mm	
Magazine Type	Flat and Convex type	
Capacity	200~300 nails	
Operating Pressure	100~120 psi	

Ø 2.1~2.9 mm  
Head Dia 5.0~7.2 mm

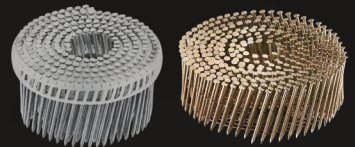
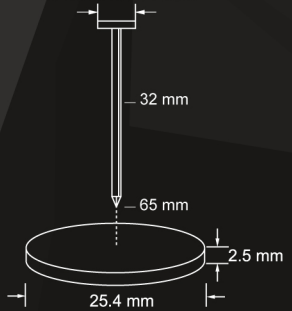

## APPLICATION

- Roofing felt
- Foam and fiberboard sheathing
- Insulation house wrap cardboard or carton to pallet

## FEATURES

- 360 degree exhaust deflector allows exhaust of air in any direction
- Depth of adjustment to countersink of flush drive nails
- Lightweight design prevents arm fatigue for user
- Drives wire and plastic sheet collated nails

# Cap Coil Nailer

Model No: CN50CP



Model No	CN50CP
L x W x H	220x110x280 mm
Weight	2.0 kgs
Shank Dia	Wire coil nails: 2.1~2.3 mm Plastic coil nails: 1.4~1.8 mm
Fastener Range	Wire coil nails: 27~50 mm Plastic coil nails: 22~38 mm
Magazine Type	Convex type
Capacity	Wire coil nails: 400 pcs Plastic coil nails: 200 pcs
Operating Pressure	100~120 psi

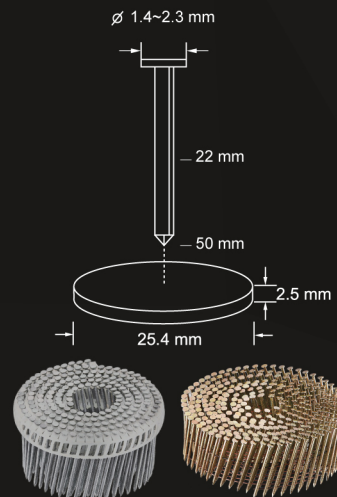

## APPLICATION

- Roofing felt
- Foam and fiberboard sheathing
- Insulation house wrap cardboard or carton to pallet

## FEATURES

- 360 degree exhaust deflector allows exhaust of air in any direction
- Depth of adjustment to countersink of flush drive nails
- Lightweight design prevents arm fatigue for user
- Drives wire and plastic sheet collated nails
- Use plastic cap, metal cap, stainless cap, waterproof stainless cap

# 21 GA. Cap Stapler

Model No: 8016WS



Model No	8016WS
L x W x H	200x120x274 mm
Weight	1.5 kgs
Gauge	21 GA.
Crown	12.8 mm
Wire Size	0.95x0.65 mm
Plastic Cap Size	25.4 mm
Fastener Range	5~16 mm

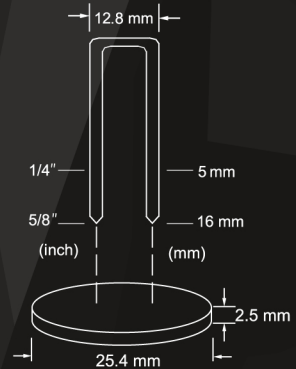

## APPLICATION

- House wrap
- Roofing felt
- Insulation board and built-up
- Modified or single-ply roof decks

## FEATURES

- Lightweight design prevents arm fatigue for user
- Fast easy bottom loading
- Ergonomic comfort handgrip provides a firm grip on tool
- Available for bump and single fire
- Make cap stay on workpiece tightly

# 18 GA. Cap Stapler

Model No: M32PC



Model No	M32PC
L x W x H	225x130x270 mm
Weight	1.8 kgs
Crown	10 mm
Gauge	18 GA.
Wire Size	1.25x1.1 mm
Plastic Cap Size	25.4 mm
Fastener Range	10~32 mm

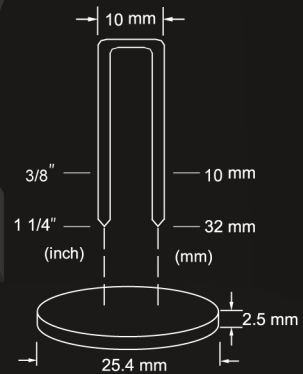

## APPLICATION

- Roofing felt
- Sheathing
- Modified or single-ply roof decks
- House wrap
- Insulation board and built-up

## FEATURES

- Lightweight design prevents arm fatigue for user
- Adjustable depth of drive
- Tool free adjustable exhaust
- Fast and easy bottom loading
- Ergonomic comfort handgrip provides a firm grip on tool
- Available for bump and single fire
- Make cap stay on workpiece tightly

Nail Depth Adjustable Dial



# Frame Wedge Nailer

Model No: FW15



Model No	FW15
L x W x H	161x48x225 mm
Weight	0.86 kgs
Crown	5 mm
Thickness	0.35 mm
Length	15 mm
Capacity	300 nails

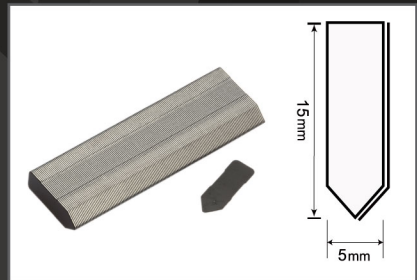

## APPLICATION

- Picture frames
- Mirror frames
- Photo frames
- Window frames

## FEATURES

- Perfect balance and light weight
- High-powered for hard wood applications
- Slide in insert to adjust the different lengths of fasteners
- Anti double shot
- Quick bottom loading
- Plastic end core provides comfort usage

# Air V-Nailer / Picture Framer Nailer

Model No: V15N, V15W



Model No	V15N	V15W
L x W x H	200x70x255 mm	
Weight	1.28 kgs	
Crown (A)	10.3 mm	10.8 mm
Height (B)	4.0~4.1 m	4.35~4.45 mm
Thickness (C)	0.3 mm	0.3 mm
Length	7, 10, 12, 15 mm	7, 10, 12, 15 mm
Nail Capacity	300 pcs	300 pcs

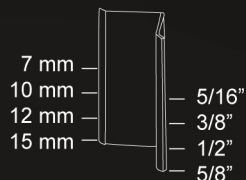
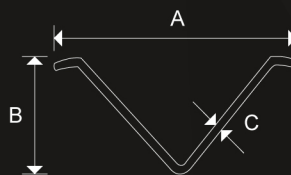

## APPLICATION

- Picture frame assembly

## FEATURES

- Lightweight design prevents arm fatigue for user
- Fast easy bottom loading
- Ergonomic comfort handgrip provides a firm grip on tool
- Durable
- Powerful



# Air V-Nailers With Bracket

Model No: V15NF, V15WF



Model No	V15NF	V15WF
L x W x H	300x200x320 mm	
Weight	5.25 kgs	
Crown (A)	10.3 mm	10.8 mm
Height (B)	4~4.1 mm	4.35~4.45 mm
Thickness (C)	0.3 mm	0.3 mm
Length	7, 10, 12, 15 mm	7, 10, 12, 15 mm
Nail Capacity	300 pcs	300 pcs

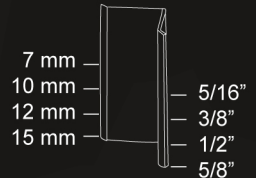
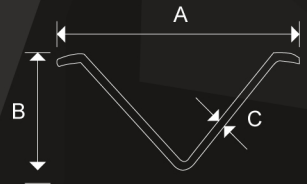

## APPLICATION

- Picture frame assembly

## FEATURES

- Optional shaft makes work easier
- Fast easy bottom loading
- Ergonomic comfort handgrip provides a firm grip on tool
- Durable
- Powerful

# Polymer Stapler

Model No: 81P, 82P, 83P



Model No	81P	82P	83P
L x W x H	216x43x148 mm		
Weight	0.9 kgs		
Gauge	19 GA.	16 GA.	16 GA.
Crown (A)	12.7 mm	12.7 mm	11.0 mm
Width(B)xThickness(C)	1.10x1.25 m	1.40x1.85 mm	1.60x1.50 mm
Length(D)	6~16 mm		
Working Pressure	70~110 psi		
Capacity	90 pcs	60 pcs	100 pcs
Equivalent	Omer 81P	Omer 82P	Omer 83P
Suitable Fastener	Raptor S/05	Raptor SH/05	Raptor SH/04

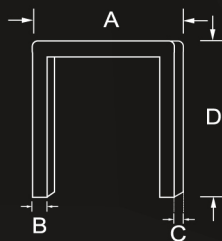

## APPLICATION

- Lumber wrap
- Lumber tagging
- Boatbuilding
- Casket lining
- Doors metal detectors
- Furnitures
- Fiberglass layup
- Upholstery
- Insulating sheathing
- All applications where metal fasteners can damage tools and to avoid fasteners removal

## FEATURES

- Comfortable handle with rubber
- Strong and light weight die cast housing
- Fast and easy down-loading

# Powder Actuated Tool

Model No: D450

■ All Spare Parts Are Compatible With Hilti DX450



Model No	D450
L x W x H	350x55x180 mm
Weight	3.2 kgs
Cartridge	6.8/11 mm Black, Red, Yellow, Green

## APPLICATION

- Wood and metal to concrete or steel
- Electrical installations (switchboxes)
- Mouldings brackets, sections etc
- General and special contractors
- Plant maintenance
- Woodworking, electrical installation
- Mechanical installation (plumbing, heating and air conditioning)
- Clips, clamps and rings for electric cables, conduits and pipes
- Interior finishing
- Plastering

## FEATURES

- This powder-actuated tool has a report silencer, power regulation and automatic cartridge feed
- It is suitable for a wide range of fastenings to steel, concrete and hard masonry
- With this piston tool, fasteners cannot ricochet or be shot through walls
- In addition, contact, drop firing and loading safety devices ensure absolute safety for the operator
- Supplied in a tough plastic tool box with safety and cleaning equipment in the standard kit

## VARIOUS PISTONS ARE AVAILABLE



# Mattress Staplers

Model No: MS1619D, MS1619S, MS1625D, MS1625S

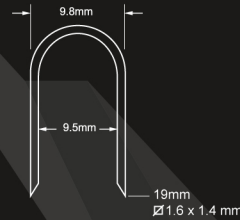

MS1619D, MS1619S

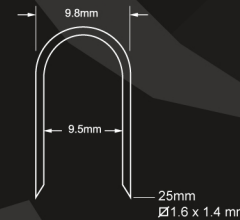

MS1625D, MS1625S



## APPLICATION

- Attaching spring to box frame

## FEATURES

- Pneumatic stapler for driving staples into hard to reach places such as bottoms of coil springs
- Available in double staple fire version

Type	Double Shooting Type		Single Shooting Type	
	MS1619D	MS1625D	MS1619S	MS1625S
Model No	MS1619D	MS1625D	MS1619S	MS1625S
L x W x H (mm)	445x46x900	445x46x900	445x46x900	445x46x900
Weight (kgs)	3	3	3	3
Gauge	16 GA	16 GA	16 GA	16 GA
Staples Crown	9.8 mm / 9.5 mm	9.8 mm / 9.5 mm	9.8 mm / 9.5 mm	9.8 mm / 9.5 mm
Wire Size	1.6x1.4 mm	1.6x1.4 mm	1.6x1.4 mm	1.6x1.4 mm
Fastener Length	19 mm	25 mm	19 mm	25 mm
Air Consumption / 90ps	0.7 cfm	0.7 cfm	0.7 cfm	0.7 cfm
Cycle Rate	4~6 staples/second	4~6 staples/second	4~6 staples/second	4~6 staples/second
Loading Capacity	100 pcs	100 pcs	100 pcs	100 pcs
Working Pressure	70~120 psi	70~120 psi	70~120 psi	70~120 psi

# Decorative Nailer with Magazine

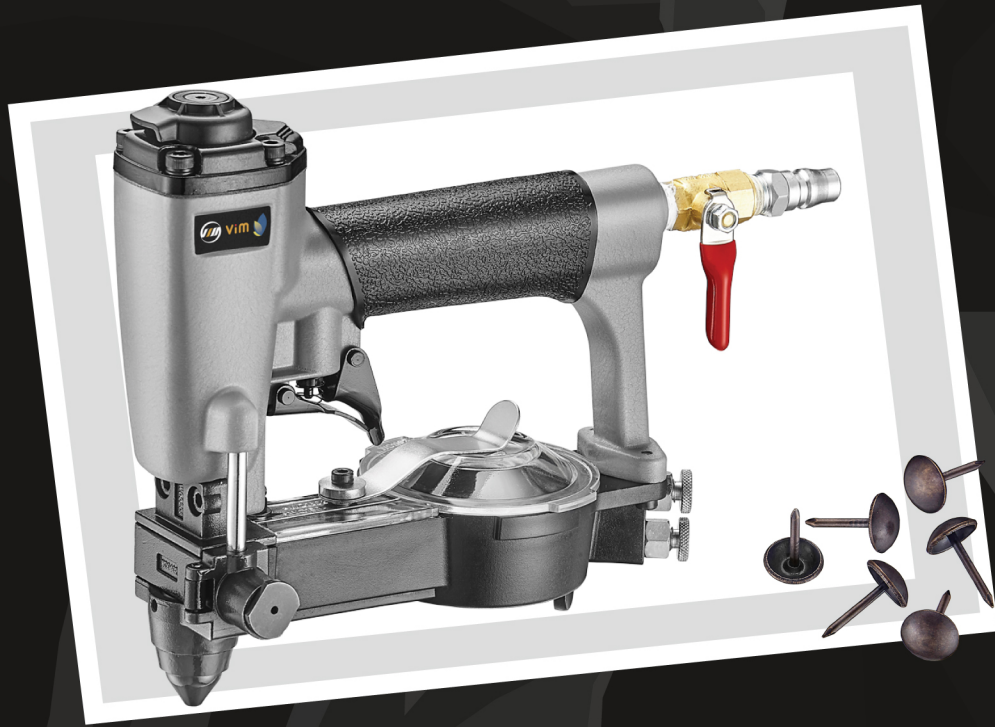

L x W x H	250x100x200 mm
Weight	1.1 kgs
Capacity	100 pcs

Model No	Head Dia (A)	Head Thickness (B)	Length (C)
DN1013AA	8.5 ~ 10.5 mm	3.4 ~ 4.0 mm	10.0 ~ 12.5 mm
DN1013AB	8.5 ~ 10.5 mm	2.5 ~ 3.0 mm	10.0 ~ 12.5 mm
DN1013AC	8.5 ~ 10.5 mm	2.8 ~ 3.3 mm	10.0 ~ 12.5 mm
DN1013AD	6.0 ~ 8.5 mm	2.0 ~ 2.5 mm	10.0 ~ 12.5 mm
DN1013AE	9.5 ~ 11.6 mm	3.7 ~ 4.4 mm	10.0 ~ 12.5 mm
DN1013AF	7.0 ~ 9.0 mm	2.8 ~ 3.3 mm	10.0 ~ 12.5 mm
DN1013AG	9.5 ~ 11.6 mm	3.1 ~ 3.6 mm	10.0 ~ 12.5 mm
DN1013AH	6.0 ~ 8.5 mm	1.6 ~ 2.0 mm	10.0 ~ 12.5 mm
DN1013AI	6.0 ~ 8.5 mm	2.8 ~ 3.3 mm	10.0 ~ 12.5 mm

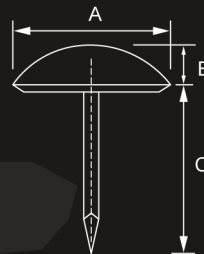

## APPLICATION

- Upholstery
- Automotive trim
- Bar & dining chair
- Chesterfield & Reproduction furniture
- Shoes
- Picture frames
- Light trim and moulding

## FEATURES

- 360° adjustable exhaust
- 100 pcs high capacity
- Loading by loose nail, automatic feeding
- Control auto feed speed by air
- Exposed nail tip design fire in the hole for faster, more precise nailing
- Up-shooting feasible

## APPLICATION :

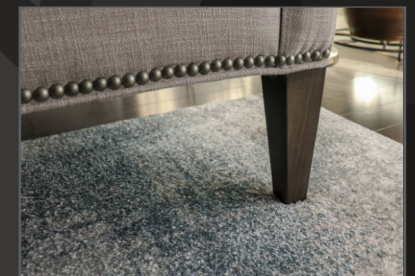

# Decorative Nailer With Magazine

Model No: DN1016AA, DN1016AB, DN1016AC  
DN1016AE, DN1016AG

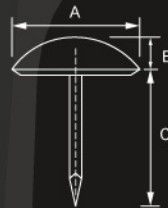

L x W x H	250x100x200 mm
Capacity	100 pcs
Weight	1.1 kgs

## APPLICATION :

Model No	Head Dia (A)	Head Thickness (B)	Length (C)
DN1016AA	8.5~10.5 mm	3.4~4.0 mm	10.0~15.5 mm
DN1016AB	8.5~10.5 mm	2.5~3.0 mm	10.0~15.5 mm
DN1016AC	8.5~10.5 mm	2.8~3.3 mm	10.0~15.5 mm
DN1016AE	9.5~11.6 mm	3.7~4.4 mm	10.0~15.5 mm
DN1016AG	9.5~11.6 mm	3.1~3.6 mm	10.0~15.5 mm



## APPLICATION

- Upholstery
- Automotive trim
- Bar & Dining chair
- Chesterfield & Reproduction furniture
- Shoes
- Picture frame
- Light trim and moulding



## FEATURES

- 360° adjustable exhaust
- 100 pcs of nail loading per time
- Loading by loose nail, automatic feeding
- Control auto feed speed by air
- Exposed nail tip design fire in the hole for faster and more precise nailing



# Decorative Nailer With Magazine

Model No: DN1020AE



Model No	DN1020AE
L x W x H	250x100x210 mm
Capacity	100 pcs
Weight	1.26 kgs
Length	16.0~23.8 mm
Head Thickness	3.6~4.4 mm
Head Diameter	9.5~11.6 mm

## APPLICATION :



## APPLICATION

- Upholstery
- Automotive trim
- Bar & Dining chair
- Chesterfield & Reproduction furniture
- Shoes
- Picture frame
- Light trim and moulding

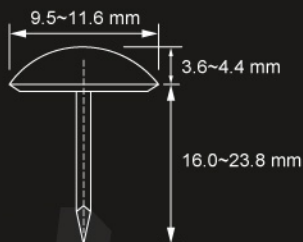

## FEATURES

- 360° adjustable exhaust
- Catch one nail and shoot one nail per time
- Need to use the nail fix table
- Exposed nail tip design fire in the hole for faster and more precise nailing

# Decorative Nailer Without Magazine

Model No: DN0916A09



Model No	DN0916A09
L x W x H	230x45x180 mm
Capacity	1 pc
Weight	0.75 kgs
Length	9.0~16.0 mm
Head Diameter	9.0 mm

## APPLICATION :



## APPLICATION

- Upholstery
- Automotive trim
- Bar & Dining chair
- Chesterfield & Reproduction furniture
- Shoes
- Picture frame
- Light trim and moulding

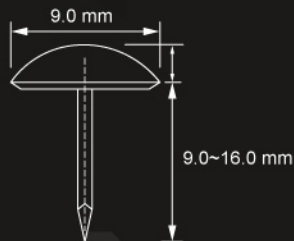

## FEATURES

- 360° adjustable exhaust
- Catch one nail and shoot one nail per time
- Need to use the nail fix table
- Exposed nail tip design fire in the hole for faster and more precise nailing



# Decorative Nailer Without Magazine

Model No: DN0919A12



Model No	DN0919A12
L x W x H	230x45x180 mm
Capacity	1 pc
Weight	0.75 kgs
Length	9.0~19.0 mm
Head Diameter	11.8 mm

## APPLICATION :



## APPLICATION

- Upholstery
- Automotive trim
- Bar & Dining chair
- Chesterfield & Reproduction furniture
- Shoes
- Picture frame
- Light trim and moulding

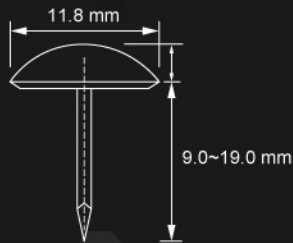

## FEATURES

- 360° adjustable exhaust
- Catch one nail and shoot one nail per time
- Need to use the nail fix table
- Exposed nail tip design fire in the hole for faster and more precise nailing

# Decorative Nailer Without Magazine

Model No: DN1223A16



Model No	DN1223A16
L x W x H	245x55x205 mm
Capacity	1 pc
Weight	0.96 kgs
Length	12.0~23.0 mm
Head Diameter	16.0 mm

## APPLICATION :



## APPLICATION

- Upholstery
- Automotive trim
- Bar & Dining chair
- Chesterfield & Reproduction furniture
- Shoes
- Picture frame
- Light trim and moulding

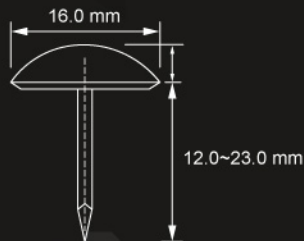

## FEATURES

- 360° adjustable exhaust
- Catch one nail and shoot one nail per time
- Need to use the nail fix table
- Exposed nail tip design fire in the hole for faster and more precise nailing

# Decorative Nailer Without Magazine

Model No: DN1223A19



Model No	DN1223A19
L x W x H	245x55x205 mm
Capacity	1 pc
Weight	0.96 kgs
Length	12.0~23.0 mm
Head Diameter	19.0 mm

## APPLICATION :



## APPLICATION

- Upholstery
- Automotive trim
- Bar & Dining chair
- Chesterfield & Reproduction furniture
- Shoes
- Picture frame
- Light trim and moulding

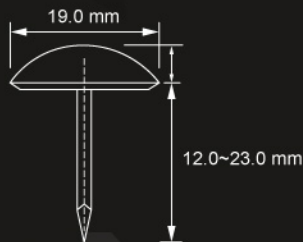

## FEATURES

- 360° adjustable exhaust
- Catch one nail and shoot one nail per time
- Need to use the nail fix table
- Exposed nail tip design fire in the hole for faster and more precise nailing

# Decorative Nailer Without Magazine

Model No: DN1427A22



Model No	DN1427A22
L x W x H	245x55x205 mm
Capacity	1 pc
Weight	0.96 kgs
Length	14.0~27.0 mm
Head Diameter	22.0 mm

## APPLICATION :



## APPLICATION

- Upholstery
- Automotive trim
- Bar & Dining chair
- Chesterfield & Reproduction furniture
- Shoes
- Picture frame
- Light trim and moulding

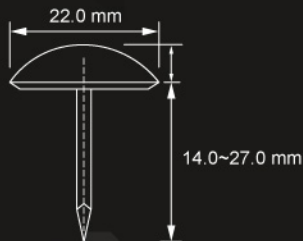

## FEATURES

- 360° adjustable exhaust
- Catch one nail and shoot one nail per time
- Need to use the nail fix table
- Exposed nail tip design fire in the hole for faster and more precise nailing

# Decorative Nailer Without Magazine

Model No: DN1427A25



Model No	DN1427A25
L x W x H	245x55x205 mm
Capacity	1 pc
Weight	0.96 kgs
Length	14.0~27.0 mm
Head Diameter	25.0 mm

## APPLICATION :



## APPLICATION

- Upholstery
- Automotive trim
- Bar & Dining chair
- Chesterfield & Reproduction furniture
- Shoes
- Picture frame
- Light trim and moulding

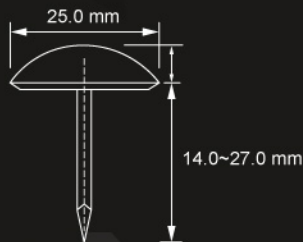

## FEATURES

- 360° adjustable exhaust
- Catch one nail and shoot one nail per time
- Need to use the nail fix table
- Exposed nail tip design fire in the hole for faster and more precise nailing